

- LIGHT SOURCES: twenty-eight
- CANOPY: white powder-coated 1100mm (43") x 370mm (14.5")
- LAMPING: 10w xenon
- LENGTH OF COPPER: 6000mm (20') maximum
- MATERIALS: Blown glass, powder-coated steel canopy, flexible copper tubing and copper hardware
- WEIGHT: approximately 75kg (165lb)
- TRANSFORMERS: remote mounted
- CONNECTION: headphone jack connected
- INSTALLATION: preset lengths, composed during installation

DESCRIPTION

The 38.28 is a 38 series chandelier with 28 light sources and 20 moons. The 38 series is an extension of the blown glass technique introduced in the 28 series. In this case, there are 4-6 cavities blown within each pendant, 3 of which house light sources, while the remainder are deep enough to house plants.

Electricity and suspension are achieved using stiff copper tubing, which is allowed to tangle and crinkle, seemingly without regard for gravity. Once in a while these copper tubes loop around moon white planters, which appear to have escaped from the confines of the lit clear glass spheres.

APPLICATIONS

The 38.28 is designed to be used in applications where the intent is to create a horizontal spread of pendants and foliage. This chandelier works best in groupings where the copper can be manipulated between multiple canopies to allow for limitless composition.

Popular residential and commercial applications include clusters over tables in dining rooms and restaurants, accessory lighting in living rooms and baths, linear configurations over bars and kitchen islands, large clusters in foyers and lobbies in both private and public spaces, as well as single chandeliers as points of interest.

NOTES

- + The installation of the 38 is more involved than other chandeliers due to the manipulation and composition of the copper tubing.
- + These standard chandeliers can be used in an infinite variety of groupings to create cohesive installations, with single pendants bridging from canopy to canopy.
- + Air plants and/or succulents recommended (not included).
- + Prior to watering the plants, please wait for the glass to cool down.

Worldwide patents pending
Made in Vancouver, Canada

BOCCI Vancouver
info@bocci.ca
www.bocci.ca

BOCCI Berlin
europe@bocci.ca
www.bocci.ca

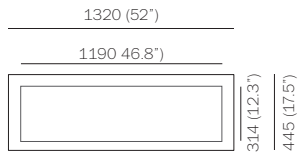

1

Measure and mark out the chandelier canopy position on the ceiling.

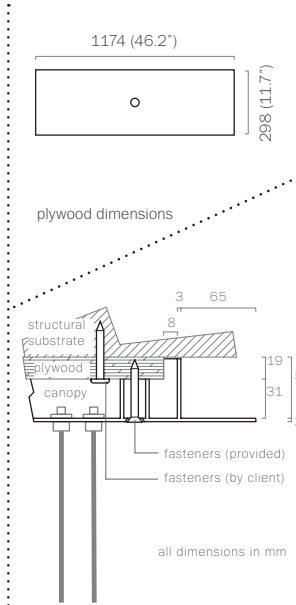

2

Note: The client is responsible for providing a robust 3/4" (19mm) plywood backing or wood blocking to securely anchor to the structural substrate.

Connections from the plywood to the structural substrate are the client's responsibility. Measure the plywood so that it fits within the canopy side walls. (refer to detail above).

Anchor the plywood backing to the structural ceiling substrate.

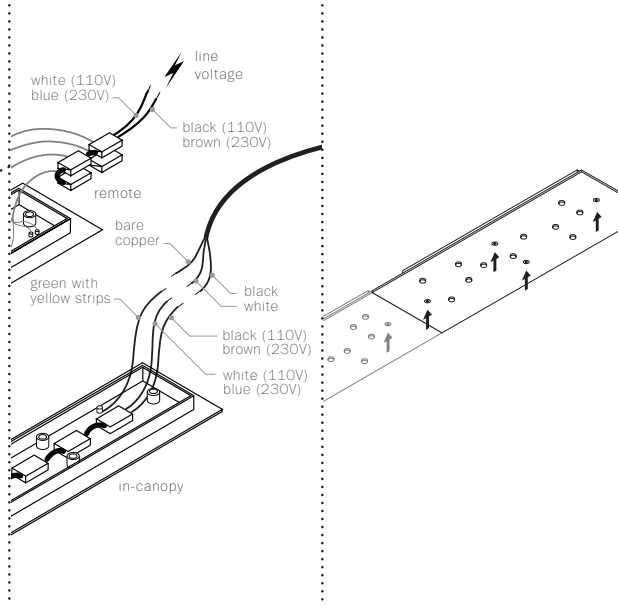

3

Connect transformers inside the canopy to line voltage. 110 V or 230 V depending on transformer.

For 110 V, connect black wire to the black wire and white wire to the white wire.

For 230 V, connect black wire to the brown wire and white wire to the blue wire.

For the ground connection, connect the green wire with yellow stripe to the bare copper wire or green wire in the junction box.

Note: As an option, Bocci recommends mounting transformers remotely in a close, accessible and hidden location for ease of long term maintenance. Installation to be done by certified personnel to insure code compliance.

4

Anchor canopy into the plywood backing using the fasteners provided.

5

Separate the copper tubes according to length.

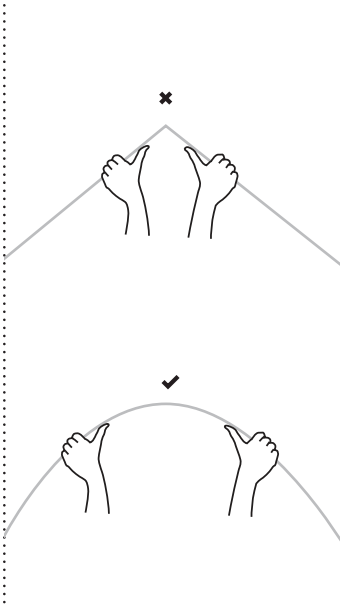

6

Very carefully uncoil the copper tube with both hands to avoid kinking.

Note: be very careful not to overbend the copper tubes as it will leave a permanent kink that can not be removed.

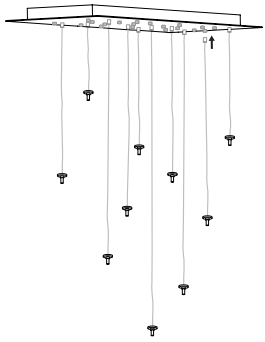

7

Install the marked shorter copper tubes for hanging the pendants. Space the tubes so the pendants will not touch one another when installed.

Each pendant terminates in a headphone jack type connector, which plugs into a receiving receptacle in the canopy.

Plug in each headphone jack connector and turn the threaded barrels into place ensuring it is adequately tightened.

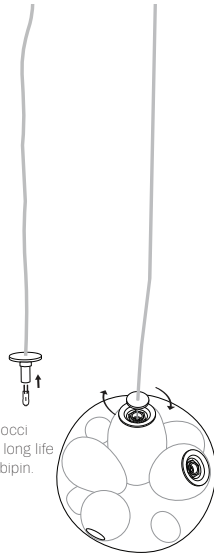

10W Bocci
24.1.1 long life
xenon bipin.

8

Bocci 24.1.1 long life bipin xenon lamps are included. Plug a lamp into each socket prior to connecting to the pendant. Do not touch the lamp with your bare hands.

Determine the placement of each pendant by choosing the topmost mounting point that will allow the large cavities to face upwards in order to receive the plants.

Connect each pendant to one tube by tightening the center cap by hand. Do not over tighten.

Tighten the set screw in the cap with the allen key provided.

Note: When using a dimmer, use low voltage electronic dimmer.

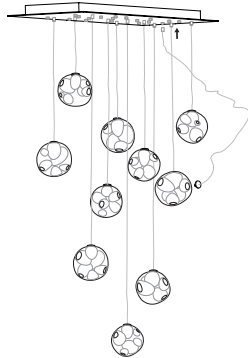

9

Install the remaining tubes to the canopy one at a time, gently bending them with both hands to avoid kinking.

The composition of the chandelier is determined by which tubes are chosen to connect to the remaining pendant mounting points.

In most configurations the longer tubes will coordinate with the longer pendants.

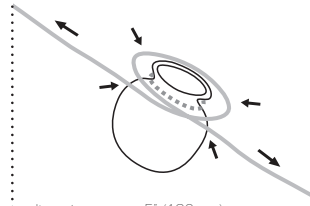

diameter approx. 5" (130mm)

10

Prior to connecting the remaining tubes to the pendants, be sure to install the glass moons, one moon per tube.

When installing the moons, first gently form a loop with the tube approximately 5" (130 mm) in diameter in the location of your choice. Insert the moon into the loop and tighten the loop around the moon, using the glass lip as a guide.



11

Once the moons are installed, install lamps before connecting the tubes to the pendants.

Connect the tubes to the pendants by tightening the center cap by hand. Shape the tubes in any direction to create a composition to your liking, taking care to fill gaps and create an appearance of weightlessness.

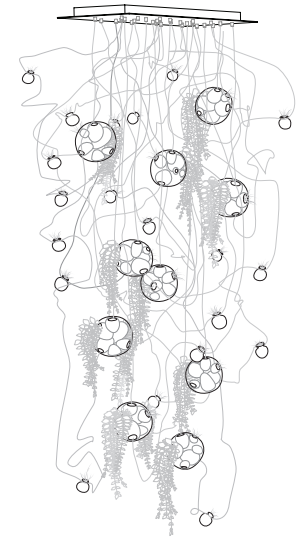

12

Place the plants into the pendant and moon cavities as desired. Reshape the tubes as needed.

Note: Bocci recommends succulents and/or air plants (plants not included).

Turn chandelier on.

*

Purchase replacement lamps online at www.bocci.ca/lamps

For additional assistance, please contact Bocci:

BOCCI Vancouver
info@bocci.ca
www.bocci.ca

BOCCI Berlin
infoeu@bocci.ca
www.bocci.ca

Made in Canada